



Founding Member of the
Midwest Sports/Ski Council

ULLR SKI, BIKE & SOCIAL CLUB

February
2014

HAVE YOU VISITED US ON THE WEB LATELY? WWW.ULLR.ORG

THE HOLIDAY BALL

The 2013 Holiday Ball is history—and a good one! Once again 79 energetic, hungry ULLRs attended the Holiday Ball at the Officers' Club despite it being Thanksgiving weekend. The food was delicious and the Changing Times Band played Christmas songs and old time rock'n roll, which everyone seemed to enjoy. Toys for Tots filled one long table. The centerpieces by "The Flower Box"

were a pretty variety of greenery with red carnations and everyone was hoping to win one. The Foundation had name drawings for "Thank You" gifts. The committee, Sharon Marini, Mary Ellen Gabel and Diane Erlandson, did great work. They had a special thank you to Tom and Mary Vande Hei — Mary for taking pictures and Tom for spending Sunday afternoon sizing them to specifications. Thank you all for coming!



Co-chairs: Diane E, Mary Ellen G, and Sharon M



Sigrid & Ted M



On the dance floor, Mary & Tom V



Dick J & Sunny Z

GREET FELLOW ULLRS AT THE WINTER GENERAL MEETINGS

Dates: **Thursday, February 13** – listen and dance to 1960's music;
Thursday, March 13 – learn some easy square dances

Location: Marian Knights of Columbus Hall
1114 American Blvd., Bloomington, MN 55420

Times: 6:30 PM Socializing
7:00 PM Meeting followed by program

Details: The KC Hall will set aside a special area upstairs for ULLRs. The dining area opens at 5:00 PM. **Please contact Lisa at 952-888-1492 to reserve space.** Let her know how many persons are attending and arrival time. The cost of the meals and drinks, including those at the Social Hour, are credited to the club to help defray the rental cost of the meeting room. [See ULLR directory for map].



Eileen Ronning led us in line dancing
at the November meeting

2014 IMPORTANT CONTACTS

OFFICERS OF THE CLUB

President

Cheryl Rogers: UllrPrez@ullr.org

Executive VP

Mary Ellen Gabel: ExecVP@ullr.org

Ski Programs VP

Pam Anderson: SkiVP@ullr.org

Summer Programs VP

Mary Ellen Goriesky: SummerVP@ullr.org

Membership VP

Carol Bush: MembershipVP@ullr.org

Acting Treasurer

Carol Bush: Treasurer@ullr.org

Secretary

Marcia Switenki: Secretary@ullr.org

Past President/Advisor

Nancy Sand: PastPrez@ullr.org

PROGRAM COORDINATORS

Alpine

Barb Kolbe: See directory

Nordic

Karen Holmquist: Nordic@ullr.org

Ski Racing

Brian Johnson: Racing@ullr.org

What's Cookin' Cashier

Nadine Carr: WCcashier@ullr.org

What's Cookin' Supply Chairs

Karen & David Oakland:

WhatsCookin@ullr.org

What's Cookin' Beverage Chairs

Joyce Bolt, Manfred Deutsch & Dale Evans

Beverages@ullr.org

Biking

John Stiefel: Biking@ullr.org

Singles

Margie Seklund: Singles@ullr.org

Folding Parties

Patty Fitzgerald & John Stiefel:

FoldingParty@ullr.org

General Meetings

Mary Ellen Gabel: ExecVP@ullr.org

MSC Representatives

Pam Anderson: SkiVP@ullr.org

Dolly Eastman: MSCrep@ullr.org

ULLR Foundation President

Jerry Weiskopf: See directory

COMMUNICATION

ULLR Webmaster

(JJ) Joe Coursolle: Webster@ullr.org

Nullr Editor

Margie Deutsch: Nullr@ullr.org

ULLRnet

Fran & Gary DeWell: Ullrnet@ullr.org

Nullr design & printing by Cornerstone Copy Center

LETTER FROM THE PRESIDENT

By Cheryl Rogers



The ULLR Board has appointed Gary Gray (chair), Sharon Marini and Pat Nelson to serve on the Nominating Committee to fill the 2014 Board. We have six vacancies: President, Ski Programs VP, Summer Programs VP, Membership VP, Treasurer and Secretary. Mary Ellen Gabel has agreed to run again for Executive VP. I will become the Past President Advisor.

Pam Anderson, Mary Ellen Goriesky, Carol Bush, Jim Maiser, Marcia Switenki and Nancy Sand all deserve praise and gratitude for serving in their positions. Don't be shy; congratulate them for donating their time and talent to our club.

Every one of the members listed in our ULLR Directory benefit from having a well-run club. The ULLR Board is responsible for this. I see many of the same people volunteering in Board and Coordinator positions. I also look at the Directory and see many people who don't volunteer. If you haven't held a position on the Board before, please consider saying "yes" when one of the Nominating Committee members contacts you. Or, if you previously served several years ago and would be willing to "re-up", please let a Nominating Committee member know. If you are willing to serve in one of the Board openings, call Gary, Sharon or Pat and let them know. They may not personally know you.

In case you aren't aware, each Board member gets their own three ring notebook. It is kind of a "how to" book for the position in which the member serves. I was very impressed on how previous Boards had done a wonderful job of including all kinds of information to make it easier to serve in one's position. Know that there are many resources to help you.

Finally, the ULLR Ski, Bike & Social Club is unique in providing ski activities for 60+ years. The club was started when skiing in the Midwest was just beginning to take off with many small ski areas using tow ropes to get up the hills. T-Bars, Poma-lifts and chair lifts were not available yet, but ski areas only charged 75 cents to ski! We have come a long way. We have made good ULLR friends and have had many good times. I know you want this to continue and so do I. It will be a sad day if we can't find volunteers willing to serve on the Board.

FEBRUARY MEMBERSHIP SPOTLIGHT

By Carol Bush, Membership VP

[This information does not appear in the online Nullr for security reasons.]

PLEASE WELCOME THIS NEW MEMBER!

J.R. HOLM

**ULLR Cancellation and Communication Policies
can be reviewed at www.ullr.org**

ULLR Webmaster: JJ [Joe] Coursolle
PO Box 201409, Bloomington, MN 55420

Email: webster@ullr.org

Phone: 612-750-0927

Nullr Editor: Margie Deutsch
8940 Northwood Pkwy, New Hope, MN 55427

Email: nullr@ullr.org

Phone: 763-545-5845

UPCOMING SINGLES EVENTS [see detailed flyers on the website www.ULLR.org]

ULLR Singles' Events are open to all single ULLRs. I need to get the 2014 ULLR Calendar host list filled for the singles card/game nights for **June and September through December** as soon as possible. Please call me and let me know if and when you'd like to have it at your home. We do appreciate all of you who have participated. And if you can do it again, we would welcome it. Call me at 952-808-8141 or email me at: margie1002@juno.com Also, if you have any suggestions for other activities that you think we could do, let me know. Thank you. Margie Seklund

SINGLES CARD/GAME NIGHTS

Bring a dish to share, beverage, and any games you'd like to play.

Date: Friday, February 14, 2014 – 7:00 PM

Host: Jan Butler

Location: 13506 Larkin Drive
Minnetonka, MN 55305

RSVP: Call Jan at 952-544-8163

Date: Friday, March 14, 2014 – 7:00 PM

Host: Pam Anderson

Location: 6217 Creekview Lane North
Brooklyn Park, MN 55443

RSVP: Call Pam at 763-315-3772

Date: Friday, April 11, 2014 – 7:00 PM

Host: Audrey Kramer

Location: 8566 Powers Place
Chanhassen, MN 55317

RSVP: Call Audrey at 952-456-4687

LAS VEGAS / SINATRA-STYLE SHOW IN BLOOMINGTON

Mark your calendars! Save the date: Thursday, July 31. Eileen Ronning will bring in Frank DiSalvo from Indian Wells, CA to perform at only ONE fabulous concert in the Twin Cities, at the KC Hall in Bloomington. A block of tickets has been reserved for ULLRs and their friends.

Frank DiSalvo looks like Frank Sinatra and sings many of his popular hits. When

he sings Sinatra, he sounds like Sinatra. But DiSalvo is MORE than that! He also sounds like Nat King Cole, Dean Martin, Willie Nelson and other singers who make up the Great American Songbook. He performs at his own lounge at the famed Indian Wells Resort throughout the winter season to rave reviews from both the locals and snowbirds.

Date: Thursday, July 31, 2014

Noon: Luncheon of pasta and chicken salad, green beans, roll, beverage, and cookie

1-3:00 PM: Concert. A Cash Bar will be available and a small area for dancing will be provided.

Reservations: Call Karen Gray at 952-895-8960



DINNER &/OR BEVERAGE & MOVIE NIGHTS

Dates: Tuesdays, February 18 and March 18.
Order dinner by 6:00 PM or join in for a beverage.

Host: Sherrie Mitchell

Location: Big 10 Restaurant and Bar
1106 Main Street, Hopkins, MN 55343
www.big10restaurant.com

Movie after dinner at the close by

Mann Hopkins Cinema Six Theater

For a listing of movies call 952-931-7992 or go to www.manntheatresmn.com/locations

RSVP: Call Sherrie at 952-942-8898

SINGLES DINING

Date: Tuesday, January 28, 2014 – 11:15 AM

Location: Ciao Bella
3501 Minnesota Drive
Bloomington [or Edina], MN 55435

RSVP: **By January 26** to Ellise Lamb at 952-442-9332 or ellise.lamb@mchsi.com

Date: Tuesday, March 25, 2014 – 5:30 PM

Location: Doolittles Woodfire Grill
550 Winnetka Avenue North
Golden Valley, MN 55427 [across Hwy 55 from Brookview Park]
www.doolittles.com/locations/golden-valley

RSVP: **By March 23** to Ellise Lamb at 952-442-9332 or ellise.lamb@mchsi.com

Cost: ULLR Discounted Tickets: \$ 32.00 This includes lunch, tax, gratuity, and concert. [Reg: \$ 35.00]
No tickets will be sold at the door.

Checks payable to: Strategies for Success

Mail to: Karen Gray
13216 Pine Ridge Road
Burnsville, MN 55337

Reserved Tables: If you reserve/pay for 8 tickets at the same time, a table will be reserved for your group, based on availability.

ULLR Cancellation Policy applies.

At the February ULLR Meeting, Karen and Gary Gray will be showing a 14 minute DVD to introduce you to Frank DiSalvo. If you can't attend the February meeting, you may also view him at <http://www.youtube.com/watch?v=uFtyWjxXFjw>.

RECALLING PAST EVENTS

A sincere thanks to these ULLRs who organized and/or led an event in December or January. VOLUNTEER! Call a program coordinator with your program idea.

DECEMBER

3 – Singles ReEntry House Party

Margie Seklund

8 – French Regional Park Hike

Jim Habeck

9 – Toys for Tots Warehouse

Nancy Sand

12 – General Meeting

Mary Ellen Gabel

13 – Single Card/Game Night

Bill Handsaker

13-15 – MSC Winter Carnival

Jerry Schuster

17– ULLR Bridge Club

Joyce Krake & Dave McCaffrey

17 – Dinner &/or Beverage & Movie Night

Sherrie Mitchell

JANUARY

9 – General Meeting

Mary Ellen Gabel

10 – Single Card/Game Night

Carole Magnuson

11 – Carver Park Hike

Joyce Butler

17 – NOON Folding Party

Nancy Sand

19 – Hyland Lake Park Reserve Hike

Karen Holmquist & Linda Heintz

21 – ULLR Bridge Club

Sunny Zenk

21 – Dinner &/or Beverage & Movie Night

Sherrie Mitchell

25 – Cleary Lake Park Hike

Judy Burich

28 – Singles Dining at Ciao Bella

Ellise Lamb

ULLRS DONATE AND HELP AT TOYS FOR TOTS WAREHOUSE

By Nancy Sand

ULLRs opened their hearts and wallets to brighten the holidays for children by donating nearly \$300 in cash/ checks and eight huge bags of toys filled with games, books, stuffed animals, cars, dolls, etc.

On Monday afternoon, December 9, eleven ULLRs plus a guest came to the Toys for Tots warehouse to help sort toys. That same day Target employees also came to help, and they finished most of the sorting by the time we arrived. So, ULLRs became box-put-together experts. We, with a little help from some Target folks, put together seven pallets of boxes with 240 boxes on each pallet. You do the math – that is a lot of boxes! We unfolded, opened, folded, taped, and stacked 1,680 boxes that will be filled with toys for kids.

During previous years when we helped at the warehouse, we spent our time sorting the toys, so this year we learned another aspect of this whole program. Although it was a very cold day outside, working inside with the boxes kept us busy and active for a couple of hours. We arrived at Houlihan's just on time for happy hour and lunch, and we all plan to help at the warehouse again next year.

ULLRs assembled a mountain of boxes



Sharon T - Loading toys into a box



Wayne J – An expert with the tape machine



Vickie L and Nancy S wonder "Is there a box big enough for this toy?"

Social & Cultural Calendar – 2014

January 17 – Friday [Noon]

Folding Party

Host: Nancy Sand
15001 Burnhaven Drive
Burnsville, MN 55306
Phone: 952-435-5225

January 21 – Tuesday [Noon]

ULLR Bridge Club

Host: Sunny Zenk
3663 Park Center Blvd., #908
St. Louis Park, MN 55416
Phone: 952-920-9177

January 21 – Tuesday

Dinner &/or Beverage & Movie Night

Contact: Sherrie Mitchell
Phone: 952-942-8898

January 28 – Tuesday

Singles' Fine Dining at Ciao Bella

Contact: Ellise Lamb
Phone: 952-442-9332

February 13 – Thursday

General Meeting at KC Hall &
Back to the 60's Dance

Contact: Mary Ellen Gabel
Phone: 612-789-7832

February 14 – Friday

Singles' Card/Game Night

Host: Jan Butler
13506 Larkin Drive
Minnetonka, MN 55305
Phone: 952-544-8163

February 18 – Tuesday [Noon]

ULLR Bridge Club

Host: Nancy Devitt
11824 Bren Road
Minnetonka, MN 55343
Phone: 952-945-9595

February 18 – Tuesday

Dinner &/or Beverage & Movie Night

Contact: Sherrie Mitchell
Phone: 952-942-8898

February 21 – Friday [Noon]

Folding Party

Hosts: Patty Fitzgerald &
John Stiefel
19595 Near Mountain Blvd.
Shorewood, MN 55331
Phone: 952-470-5411

March 13 – Thursday

General Meeting at KC Hall &
Square Dancing

Contact: Mary Ellen Gabel
Phone: 612-789-7832

March 18 – Tuesday [Noon]

ULLR Bridge Club

Host: Sharon Marini
8201 York Ave. S.
Bloomington, MN 55431
Phone: 952-893-7408

March 18 – Tuesday

Dinner &/or Beverage & Movie Night

Contact: Sherrie Mitchell
Phone: 952-942-8898

March 21 – Friday [Noon]

Folding Party

Host: Mary Ellen Gabel
3213 Skycroft Dr. NE
Minneapolis, MN 55418
Phone: 612-789-7832

March 25 – Tuesday [5:30]

Singles' Fine Dining at
Doolittles Woodfire Grill

Contact: Ellise Lamb
Phone: 952-442-9332

www.ullr.org

2014 ULLR Ski Calendar

JANUARY

January 15 – Wednesday [9:30 AM]

Event: ULLRs at Welch
26685 Cty Road 7 Blvd.
Welch, MN
[Meet in Main Lodge]

January 22 – Wednesday [9:30 AM]

Event: ULLRs at Afton Alps
6600 Peller Ave S., Hastings
[Meet at Highlands Lodge]

January 28 – Tuesday [9:30 AM]

Event: ULLRs at Wild Mountain
37200 Wild Mountain Rd.
Taylors Falls, MN
[Meet in Lodge Upper level]

FEBRUARY

February 2-8, Sunday to Saturday

Event: Steamboat Ski Trip
Steamboat Springs, CO
Call about availability

Contacts: Patty Fitzgerald
& Karen Holmquist
Phones: 952-470-5411 [P]
952-431-1903 [K]

February 5 – Wednesday [9:30 AM]

Event: ULLRs at Welch
26685 Cty Road 7 Blvd.
Welch, MN
[Meet in Main Lodge]

February 11 – Tuesday [9:30 AM]

Event: ULLRs at Afton Alps
6600 Peller Ave S., Hastings
[Meet at Highlands Lodge]

February 18-20, Tuesday - Thursday

Event: Granite Peak Ski Area Trip
Wausau, Wisconsin
[see article p. 6]
Call about availability

Contacts: Nancy Sand
& Diane Erlandson
Phones: 952-435-5225 [N]
952-941-5184 [D]

February 25 – Tuesday [9:30 AM]

Event: ULLRs at Wild Mountain
37200 Wild Mountain Rd.
Taylors Falls, MN
[Meet in Lodge Upper level]

MARCH

March 4 – Tuesday [9:30 AM]

Event: ULLRs at Wild Mountain
37200 Wild Mountain Rd.
Taylors Falls, MN
[Meet in Lodge Upper level]

March 12 – Wednesday [9:30 AM]

Event: ULLRs at Afton Alps
6600 Peller Ave S., Hastings
[Meet at Highlands Lodge]

Visit our website at
www.ullr.org
for updated details

2014 Hike, Snowshoe & Cross-Country Ski Schedule

[In case of inclement weather check with the chair to see if event is canceled]

JANUARY

January 19 – Sunday – 10:45 AM

Event: Hyland Lake Park Reserve: Hike, Snowshoe or Cross Country. Meet at Richardson Nature Center, 8737 East Bush Lake Road, Bloomington, MN – Lunch after at TGI Fridays

TGI Fridays: 7731 Normandale Blvd., Bloomington

Contacts: Karen Holmquist & Linda Heintz

Phone: 952-431-1903; [c] 952-270-4739 [K]
651-454-6152; [c] 612-916-2526 [L]

RSVP by January 17

January 25 – Saturday – 11:00 AM

Event: Cleary Lake Regional Park Snowshoe, Ski-Skate or Cross Country [Three Rivers Park District cross-country pass is required. A daily pass for \$4.00 can be purchased at the Visitor's Center.] Meet at Visitors Center. 18106 Texas Avenue, Prior Lake, MN
Lunch after at Chianti Grill

Chianti: 14296 Plymouth Avenue, Burnsville, MN

Contact: Judy Burich

Phone: 952-440-3188

FEBRUARY

February 12 – Wednesday – 6:30 PM

Event: Moonlight Hike. Meet at Woodlake Nature Center Visitor Center, 6710 Lakeshore Drive W., Minneapolis, MN 55423

Contact: Bill Lyon

Phone: 612-722-8352

CARPOOL TO WAUSAU, WISCONSIN

Dates: February 18-20, 2014 – Tuesday-Thursday

Cost: \$105 per person for a king room or \$128 per person for a double queen room.

Join ULLRs to downhill ski at Granite Peak, snowshoe or cross-country at Nine Mile Forest, or snowshoe at Rib Mountain State Park. Enjoy mid-week discounted tickets and park fees.

Package includes: two nights lodging at the rustic Stoney Creek Inn, a happy hour and pizza party Tuesday evening, and Wednesday and Thursday morning breakfasts. There will be an optional group dinner on Wednesday evening.

Trip chairs: Nancy Sand – 952-435-5225
and Diane Erlandson – 952-941-5184

Call Nancy or Diane about availability.

Send checks payable to “ULLR Ski Club” to:

Diane Erlandson

8200 West 33rd Street, #302

St. Louis Park, MN 55426

ULLR CANCELLATION POLICY APPLIES

February 15 – Saturday – 12:30 PM

Event: Lake Rebecca Park Reserve: Hike, Snowshoe or Cross Country. Meet at Lowry Nature Center, 9831 Rebecca Park Trail Rockford, MN 55373
Dinner after at Axel's Tavern

Axel's: 130 Railway Street, Loretto, MN

Contact: Pam Anderson

Phone: 763-315-3772, [c] 763-639-2532

MARCH

March 1 – Saturday – 1:00 PM

Event: Baker Park Reserve: Cross-country or Snowshoe
Lunch after at Axel's Tavern

Axel's: 130 Railway Street, Loretto, MN

Contact: Jim Habeck

Phone: 753-559-5593

March 8 – Saturday – 10:00 AM

Event: Elm Creek Park Reserve: Snowshoe or Cross Country. Meet at main building off Hwy. 81 & Elm Creek Pkwy [12400 James Deane Parkway, Maple Grove]
Lunch after at Maple Tavern

Maple Tavern: 9375 Deerwood Lane N., Maple Grove [corner of Hwy. 81 & 93rd Ave.]

Contact: Jim Habeck

Phone: 753-559-5593 [RSVP by March 6]

MSC TRIP TO LUTSEN

By Margie Deutsch

MSC took 150 skiers to Lutsen December 13-15, 2013, for the annual Winter Carnival. Three buses took skiers to the ancient Sawtooth Mountains that rise 1,000 feet above the north shore of Lake Superior. The scenery is breathtaking and the runs are challenging and fun.

13 of the 16 ULLRs left on the Friday morning 7:00 AM bus. They enjoyed a half day of skiing and really approved of the new, faster six-passenger high-speed chair lift on Moose Mountain. All of the MSC skiers had hill-side accommodations. There was “turtle racing” Saturday afternoon. [ULLR Manfred came in 2nd!] It was again a great day of skiing. Sunday had bitter cold winds and temperatures; therefore, skiing was limited to the more sheltered interior mountain slopes on Eagle and Ullr Mountains. Everyone agreed it was a good trip.

ULLR BRIDGE

Another great day of bridge was held on November 19th at Carol Burgess' house. There were enough players for four tables which made a fun day for all. Winners for the day were 1st place Carol Burgess, 2nd place Maryann Schwebel, and in 3rd place new player Nancy Devitt. We all welcomed Nancy and she enjoyed her first day playing with the group and—winning a prize! Nancy was so happy, she will be hosting the next Bridge Day on Tuesday, February 18. Please RSVP to Nancy, 952-945-9595. [See the Social calendar for more information.]

The Audit for the year ended April 30, 2013, was completed by Joe Schwebel. No material discrepancies were found. Below are the ending Balance Sheet and Summary of Income and Expenses.

ULLR Ski, Bike and Social Club
BALANCE SHEET As of April 30, 2013

| | |
|---------------------------------------|--------------------|
| Assets | |
| Current Assets | |
| Checking, Wells Fargo | 19,958.89 |
| Door County Bike, prepaid | 608.00 |
| Prepaid expenses | 5,364.00 |
| Prepaid, Steamboat 2014 | 2,000.00 |
| Savings, Vanguard | 14,193.36 |
| Savings, Wells Fargo | 2,903.80 |
| Whitefish deposit | <u>6,463.92</u> |
| Total Current Assets | 51,491.97 |
| TOTAL ASSETS 51,491.97 | |
| Liabilities & Equity | |
| Liabilities | |
| Deposits, Deferred Revenue | 19,647.30 |
| Paul Bunyon Bike, Deposit | 1,796.00 |
| Whitefish Deferred | <u>2,928.00</u> |
| Total Current Liabilities | 24,371.30 |
| Total Liabilities | 24,371.30 |
| Equity | |
| Opening Balance Equity | 37,535.08 |
| Net Income | <u>(10,414.41)</u> |
| Total Equity | 27,120.67 |
| TOTAL LIABILITIES & EQUITY | 51,491.97 |

FORT SNELLING HIKE

The 11th Annual Fort Snelling Hike on November 9, 2013, was lead by John Egan and Carolyn Buswell. These hikers dressed warmly for the 45 degree weather.



Back Row: Diana C, John E, Carolyn B, Jim S, John S, Patty F, Pam A **Front Row:** Bill L, Joyce B, Linda H, Barb K, Mary Ellen G, Nancy S

REENTRY HOLIDAY SOCIAL WITH ULLR SINGLES By Margie Seklund, ULLR Singles Coordinator

On December 3, 2013, eight ULLR singles went to the ReEntry halfway house in south Minneapolis to sing Christmas carols and socialize with the residents. We handed out Christmas bags of gifts. The residents were very pleased with all the gift items, the singing, and the interaction with the ULLR group. The staff of ReEntry provided some appetizers, Christmas cookies, and apple cider for everyone. It was a very rewarding and happy occasion. Thanks to all ULLRs who were so generous in providing clothing, toiletry items, gifts, and money to purchase gifts for all of the residents. The donations were very much appreciated, and it helped to make a more cheerful Christmas for these folks!

SUMMARY OF INCOME AND EXPENSES

| | |
|----------------------------------|--------------------|
| Events | |
| Giants Ridge | (1,023.00) |
| Sun Valley | (2,046.00) |
| Ski Utah | (413.00) |
| Good Ol' Days | 391.00 |
| Spring Banquet | (2,354.00) |
| What's Cookin' | (1,427.00) |
| Miscellaneous Event Exp | (512.00) |
| Administrative Expenses | |
| Membership | 5,279.00 |
| Nullr & Directory | (6,604.00) |
| Website | (437.00) |
| Meeting | (408.00) |
| Insurance | (318.00) |
| Dues | (359.00) |
| Office supplies | <u>(183.41)</u> |
| Total Income and Expenses | (10,414.41) |

BIKE PLANNING PARTY

Please come to the bike planning party and bring your ideas for bike rides for the upcoming biking season.

Date: Sunday, March 9, 2014 at 4:00 PM

Cost: \$1.00. A main dish & beverages will be provided. Please bring a side dish.

Location: John Stiefel & Patty Fitzgerald's
 9595 Near Mountain Blvd., Shorewood

RSVP: 952-470-5411 or patfitzjohns@msn.com

Directions: From 494 and Crosstown CR 62, head West on CR 62, approx. 4 mi to a stop light, which is the end of CR 62 & beginning of Hwy. 101. Go straight at that intersection and you will be on Hwy. 101 South. Take the 1st right onto Townline Rd. After a block, the road curves sharp right and becomes Vine Hill Rd. Near Mountain. Blvd is the 2nd left turn. The house is about 1½ blocks down, on the left side.

BIKE THE PAUL BUNYAN TRAIL JUNE 4-6,

Attention all bikers, shoppers, swimmers, golfers, and all who like to eat, drink, and socialize and be merry. Reserve your spot at the beautiful Good Ol' Days Resort in Nisswa next to the trail [or you may choose to stay offsite]. There are 2 and 3 bedroom villas and 2-person lodge rooms.

Cost: \$144 per person. This includes lodging, two breakfasts, and Thursday evening main dish. Everyone will be asked to contribute food.

Send checks to: Sharon Marini, 8201 York Avenue South, Bloomington, MN 55431

Make checks payable to ULLR Club. [Please include emergency contact person and their phone number with your check.] **This trip fills up quickly!**

DEADLINE IS MARCH 1, 2014

Chairs: Mary Ellen Gabel – 612-789-7832 &
 Sharon Marini – 952-893-7408

ULLR Ski, Bike & Social Club

PO Box 201409

Bloomington, MN 55420-1409

Place
Stamp
Here

Address Label

It is time to renew your membership!

Visit our website at
www.ullr.org for meeting,
event and trip news,
photos and recipes.

FOLD LINE ↓

| | |
|--|---|
| <p>Future Folding Parties:</p> <ul style="list-style-type: none"> • January 16, 2014 (at noon): Nancy Sand • March 21, 2014 (at noon): Mary Ellen Gabel • May 16, 2014 (6:30 PM): Joyce Crozier & Bill Kansas • July 18, 2014: Jean Berry | <p>Folding Parties are fun to host and attend and are a great way for members to get acquainted. Winter parties begin at 12:00 PM (noon). A main dish is provided. Please bring a snack, salad or dessert to share and a \$1.00 donation for beverages. <i>If you are interested in hosting a Folding Party, please call the Folding Party Chairs: Patty Fitzgerald & John Stiefel 952-470-5411.</i> [An allowance is provided to help defray costs.]</p> |
|--|---|

The next Folding Party is
Friday, February 21, 2014 at 12:00 PM (noon)
hosted by Patty Fitzgerald & John Stiefel
 19595 Near Mountain Blvd., Shorewood, MN 55331
Please RSVP to: Patty at 952-470-5411
(so she can plan food)

From the South: Take I-494 [west and then north] to CR 62, drive west 3-½ miles to a stop sign where a sign says Hwy 101 South. [see below, “for both”]

From the North: Take I-494 south to Hwy. 7. Go west 2-½ miles to Hwy 101 South. Turn left onto 101 South and go 1.7 miles to a stop light where 101 South makes a right turn.

For Both: Go one block on Hwy 101 South to Townline Road. Turn right. The road curves to the right and becomes Vine Hill Road. Go 2 blocks to Near Mountain Blvd. Turn left. Drive 1-½ blocks, house is on the left.

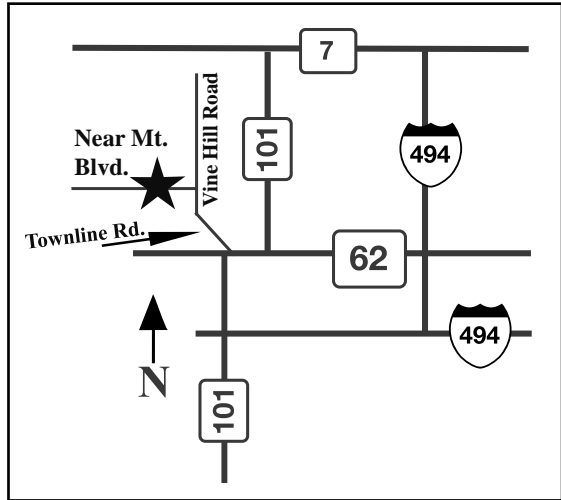

For updated details visit our website
www.ullr.org